

SKG-IKOB

Certificatie

Poppenbouwing 56,
NL-4191 NZ Geldermalsen
Postbus 202
NL-4190 CE Geldermalsen
Tel: +31(0)88-244 01 00
E-mail: info@skgikob.nl
Website: www.skgikob.nl

European Technical Assessment

ETA-16/0769
Of 01/04/2019

General part

Technical Assessment Body issuing the European Technical Assessment:
SKG-IKOB Certificatie BV

Trade name of the construction product

Passief Bouwblok

**Product family to which the
construction product belongs**

**Non load-bearing permanent shuttering kits/systems
based on hollow blocks or panels of insulating materials
and sometimes concrete**

Manufacturer

ICF Moulding BV
Ecopark 49
8305 BJ EMMELOORD
The Netherlands
Tel: +31 (0)527-620981
E-mail: info@icfmoulding.nl
Web: www.passiefbouwblok.nl

Manufacturing plants

A001

**This European Technical Assessment
contains**

23 pages including 3 Annexes which form an integral part of
this assessment.

**This European Technical Assessment is
issued in accordance with regulation
(EU) No 305/2011, on the basis of**

ETAG 009, edition June 2002, used as European
Assessment Document (EAD)

This version replaces

ETA 16/0769, version 1 issued on 30/09/2016

Translations of this European Technical Assessment in other languages shall fully correspond to the original issued document and should be identified as such.

Communication of this European Technical Assessment, including transmission by electronic means, shall be in full. However, partial reproduction may be made, with the written consent of the issuing Technical Assessment Body. Any partial reproduction has to be identified as such.

Specific parts

1 Technical description of the product:

Passief Bouwblok is a non-loadbearing permanent shuttering system based on hollow blocks made of Neopor® EPS leaves and polypropylene spacers applicable as formwork for plain and reinforced concrete walls cast in-situ.

The concrete infill structural pattern is of continuous type.

Renderings, coatings and plaster boards are not part of this ETA.

Shuttering leaves

The shuttering leaves are made of Neopor®, expanded polystyrene.

Table 1 – Dimensions Passief Bouwblok elements

	Dimensions	Inner leaf	Cavity (concrete infill)	Outer leaf
Passief Bouwblok 330 Including: - inner corner elements - outer corner elements - outer leaf fitting pieces	See annex A	60 mm	140 mm	130 mm
Passief Bouwblok 400 - inner corner elements - outer corner elements - outer leaf fitting pieces		60 mm	140 mm	200 mm

Table 2 – Dimensions Passief Bouwblok cavity capping elements

	Length	Width	Height
Horizontal cavity capping element	1200 mm	140 mm	130 mm
Vertical cavity capping element	60 mm	140 mm	200 mm

The upper and lower surfaces of the shuttering leaves are castellated and the vertical mating surfaces are tongue and mortise to form a tight fit when joined together.

Table 3 – Characteristics of Neopor® EPS

	Unity	Value
Nominal density	g/l	30
Thermal conductivity λ_D	W/mK	0,030

The inner and outer surfaces have grooves running vertically. Those grooves on the outer side allow the application of hydraulic coatings. Because of the grooves on the inner side, the concrete combines with the shuttering leaves in a perfect fit. The grooves on the inner side also form locks for end stops.

Spacers

The spacers are made from polypropylene.

The horizontal distance between the spacers is 150 mm (see Annex 1).

The shape of the spacers makes them suitable for precise location of the reinforcement bars for the concrete and secure a correct position of the reinforcement.

The two ends of the spacers are embedded in the Neopor of the shuttering leaves.
The sum of the cross-sectional areas of the spacers is less than 2% of the area of the concrete core.

The applicant has submitted a written declaration that the product and/or constituents of the product contains no substances which have been classified as dangerous according to Directive 67/548/EEC and Regulation (EC) No. 1272/2008 and listed in the 'indicative list on dangerous substances' of the EGDS – taking into account the installation conditions of the construction product and the release scenarios resulting from there.

In addition to the specific clauses relating to dangerous substances contained in this European Technical Assessment, there may be other requirements applicable to the products falling within its scope (e.g. transposed European legislation and national laws, regulations and administrative provisions). In order to meet the provisions of the Construction Products Regulation, these requirements need also to be complied with, when and where they apply.

2 Specification of the intended uses in accordance with the applicable Assessment Document (hereinafter EAD) ETAG 009.

2.1 Intended use

The Passief Bouwblok is to be used for construction of load-bearing (structural) or non-load-bearing (non-structural) external (below or above ground) and internal walls for residential and non-residential buildings, including those which are subject to fire regulations.

When using this type of construction below ground a waterproofing according to applicable national rules shall be provided.

The relevant and applicable use categories in accordance with EOTA TR 034 for the product are:

- Category IA2: product with no direct contact but possible impact on indoor air
- Category S/W 3: product with no contact to and no impact on soil, ground or surface water.

Detailed information and data is given in Annex A.

2.2 Working life

The assumed working life of the Passief Bouwblok is for the intended use 50 years, provided that the assembled product is subject to appropriate installation, use and maintenance. The indication of 50 years cannot be interpreted as a guarantee given by ICF Moulding, but should only be regarded as a means for choosing the right products in relation to the expected economically reasonable working life of the works.

3. Performance of the product and references to the methods used for its assessment

The assessment of fitness for use has been made in accordance with ETAG 009 (used as EAD).

Passief Bouwblok		
Basic requirement for constructionwork	Characteristic	Assessments of characteristics
BWR 1 Mechanical resistance and stability		
Resulting structural pattern	Geometry of the voids of the shuttering	Continuously
Efficiency of filling	Capability of the shuttering to produce a satisfactory concrete infill Tightness of the shuttering	Satisfactory
Possibility of steel reinforcement	Compatibility of the shuttering with correct reinforcement	Satisfactory
BWR 2 Safety in case of fire		
Reaction to fire	Ignitability Rate of heat release Rate of spread of flame Rate of smoke production Flaming droplets/particles	Class E
Fire resistance	Load-bearing capacity Fire integrity Fire insulation Mechanical action Radiation	Load-bearing wall REI 90
		Non load-bearing wall EI 120
BWR 3 Hygiene, health and environment		
Release of dangerous substances	Content, Rate of release of dangerous substances	"No dangerous materials"
Water vapour permeability	Water vapour permeability	NPD
Water absorption	Capillarity of the shuttering	Satisfactory
Watertightness		NPD
BWR 4 Safety in use		
Bond strength and resistance to impact load	Bond strength and resistance to impact load	NPD
Resistance to filling pressure	Mechanical characteristics of the shuttering	Satisfactory
	Pull out strength of single spacer	0.778 kN
Safety against personal injuries	Safety against personal injuries by contact	– no sharp or cutting edges – nature of surface is soft
BWR 5 Protection against noise		
Airborne sound insulation	Airborne sound insulation	
	Passief Bouwblok 330:	NPD
	Passief Bouwblok 400: – 8-10 mm plaster – 60 mm Neopor – 140 mm concrete – 200 mm neopor – 30 mm cavity – 100 mm masonry, claybrick	$R'_w(C;C_{tr}) = 50 (-1;-4) \text{ dB}$
Sound absorption	Sound absorption coefficient	NPD

BWR 6 Energy economy and heat retention		
Thermal resistance	Thermal resistance in accordance with EN ISO 6946 <i>The values R_{si} and R_{se} used to determine R_T are respectively 0.125 m²K/W and 0.043 m²K/W</i>	
	<ul style="list-style-type: none"> – 60 mm Neopor (λ_D 0.030 m²K/W) – 140 mm concrete (λ_D 2.0 m²K/W) – 130 mm neopor (λ_D 0.030 m²K/W) 	$R_T = 6.57$ m ² K/W
	<ul style="list-style-type: none"> – 60 mm Neopor (λ_D 0.030 m²K/W) – 140 mm concrete (λ_D 2.0 m²K/W) – 200 mm neopor (λ_D 0.030 m²K/W) 	$R_T = 8.90$ m ² K/W
Thermal inertia	Thermal inertia	NPD
General aspects relating to fitness for use		
Resistance to deterioration agents	Protection against deterioration caused by: <ul style="list-style-type: none"> – physical agents – chemical agents – biological agents 	NPD Not relevant Not relevant
Resistance to normal use damages	resistance to normal use damages	
	– normal use impacts	The product will be protected in use by internal finishing and external applications against normal use impacts.
	– incorporation of ducts	The instructions given in the installation guide of the ETA-holder are suitable for the realization of perforations through the walls to make pass ducts.
	– fixing of objects	The installation guide of the ETA holder shall be followed

4 Assessment and verification of consistency of performance (hereinafter AVCP) system applied, with reference to its legal base

According to the decision 98/279/EC (amended by 2001/596/EC) – Commission Decision of date 5th December 1997 on the procedure for attesting the conformity of construction products pursuant to Article 20(2) of Council Directive 89/106/EEC as regards Non load-bearing permanent shuttering kits/systems, to be filled with normal concrete and, where relevant, with reinforcement, based on either: hollow blocks made of an insulating material (or a combination of an insulating material and other materials), published in the Official Journal of the European Union (OJEU) L127 of 29/04/1998, see <http://eur-lex.europa.eu/JOIndex.do> of the European Commission¹, as amended, the system(s) of assessment and verification of constancy of performance (see Annex V to Regulation (EU) No 305/2011) given in the following table(s) applies (apply).

Product(s)	Intended use(s)	Level(s) or class(es)	System(s)
Non load-bearing permanent shuttering kits/systems, to be filled with normal concrete and, where relevant, with reinforcement, based on either: hollow blocks made of an insulating material (or a combination of an insulating material and other materials)	for the construction of external and internal walls subject to fire regulations, in buildings	A1**, A2**,B**,C**,D,E	2+

5 Technical details necessary for the implementation of the AVCP system, as provided for in the applicable EAD

Tasks of the manufacturer:

Factory production control

The manufacturer shall exercise permanent internal control of production. All the elements, requirements and provisions adopted by the manufacturer shall be documented in a systematic manner in the form of written policies and procedures, including records of results performed. This production control system shall ensure that the product is in conformity with this European Technical Assessment. The manufacturer may only use initial +materials stated in the technical documentation of this European Technical Assessment.

The factory production control shall be in accordance with the Control Plan of 1st April 2019 relating to the European technical assessment ETA 16/0769 issued on 01/04/2019 which is part of the technical documentation of this European technical approval. The "Control Plan" is laid down in the context of the factory production control system operated by the manufacturer and deposited at SKG-IKOB. The results of factory production control shall be recorded and evaluated in accordance with the provisions of the Control Plan.

Other tasks of the manufacturer

Additional information

The manufacturer shall provide a technical data sheet and an installation instruction with the following minimum information:

(a) Technical data sheet:

- Field of application:
- Building elements for which the *Passief Bouwblok* is suitable, type and properties of the building elements like minimum thickness, density, and - in case of lightweight constructions – the construction requirements.
- Limits in size, minimum thickness etc. of the products
- Construction of the *Passief Bouwblok* including the necessary components and additional products with clear indication whether they are generic or specific.

(b) Installation instruction:

- Steps to be followed
- Stipulations on maintenance, repair and replacement

Issued in Geldermalsen, the Netherlands on 01/04/2019

The original English version is signed on behalf of SKG-IKOB

By



SKG-IKOB, manager certification
ir. H.A.J. van Dartel

Annex A – Drawings

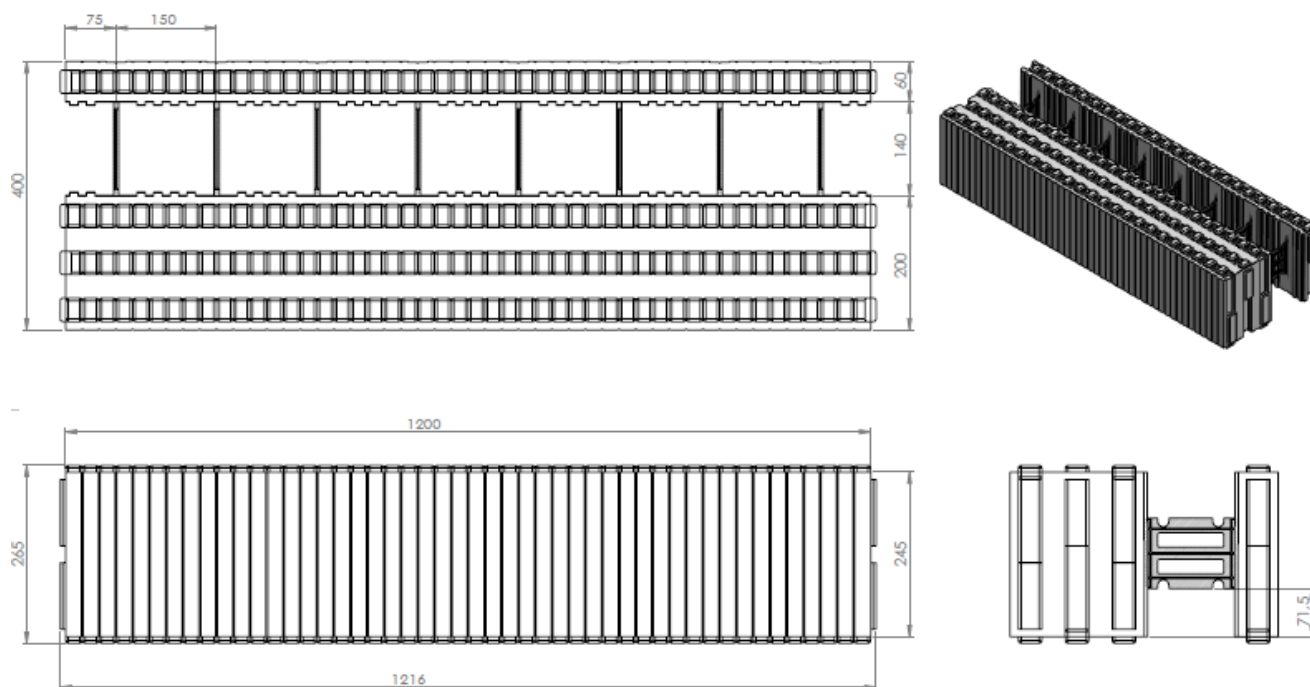

Standard Passief Bouwblok 400 element

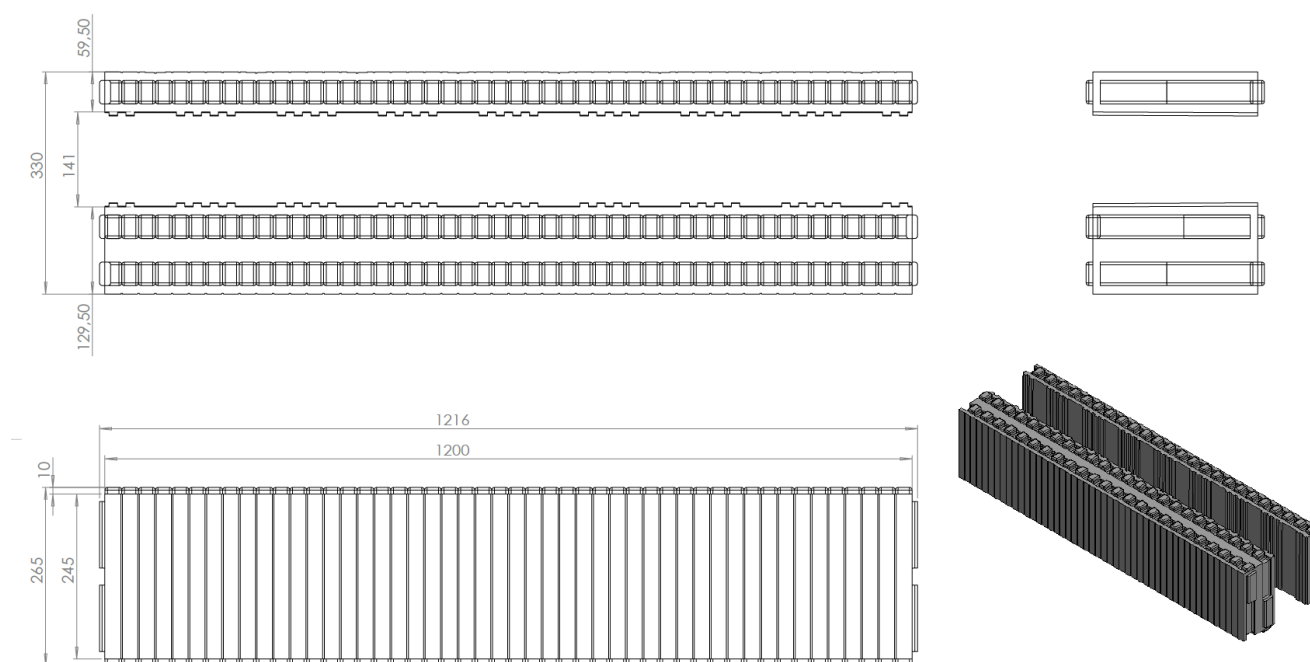

Standard Passief Bouwblok 330 element

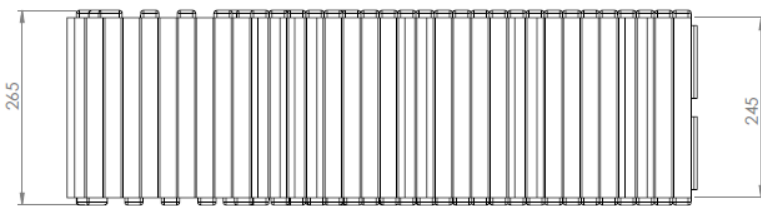
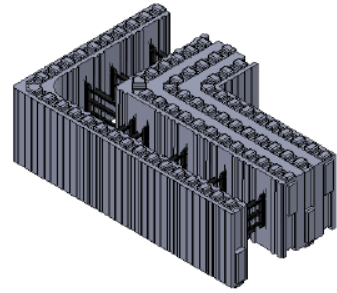
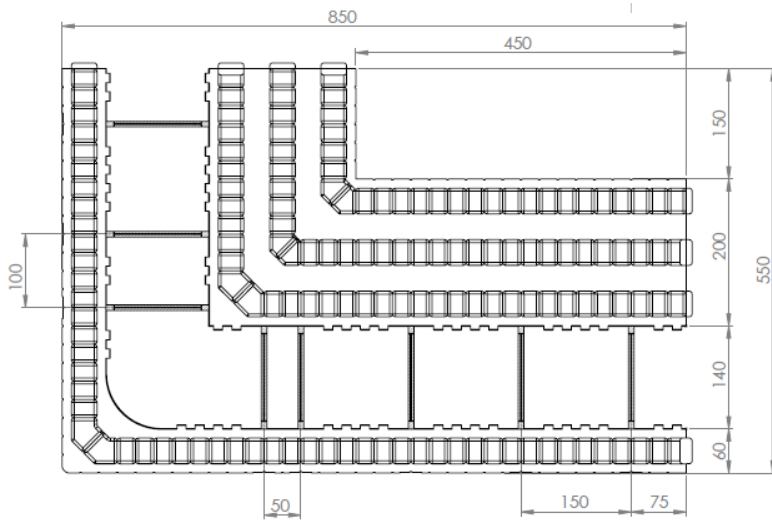

Inner corner Passief Bouwblok 400 element

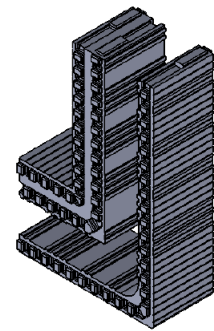
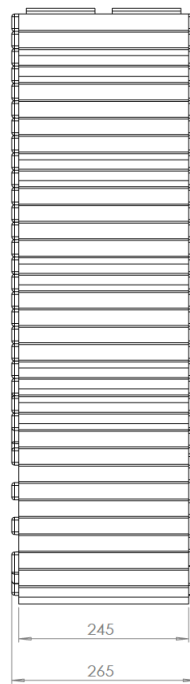
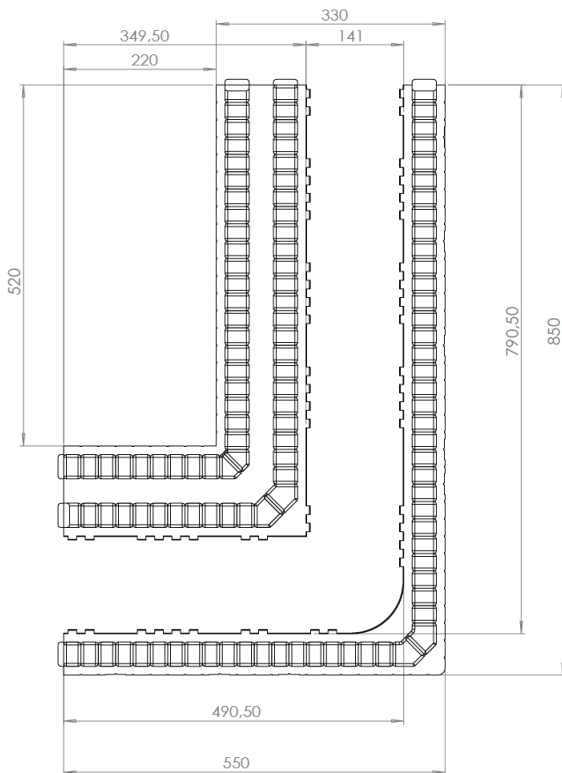

Inner corner Passief Bouwblok 330 element

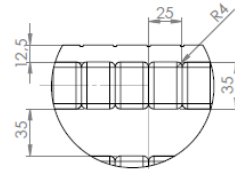
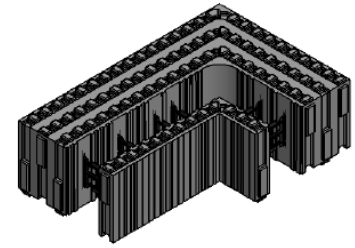
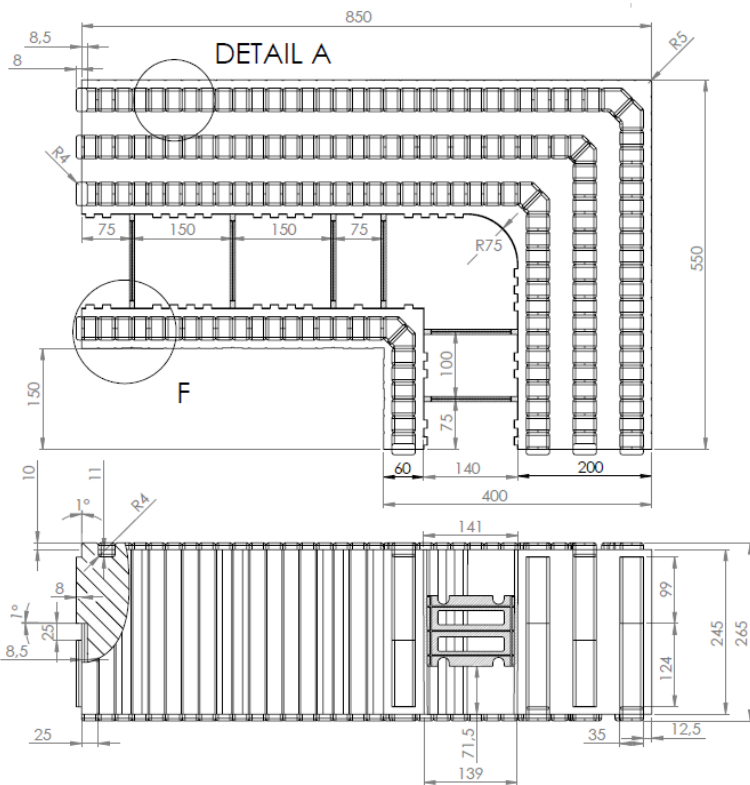

DETAIL A
Noppen
SCALE 2 : 5

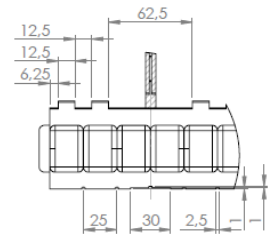

DETAIL F
Patroon zijkant
SCALE 2 : 5

Outer corner Passief Bouwblok 400 element

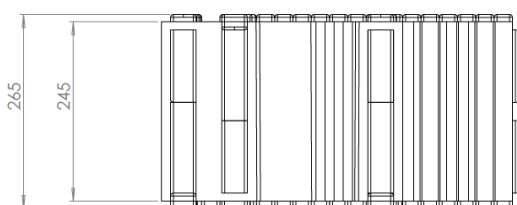
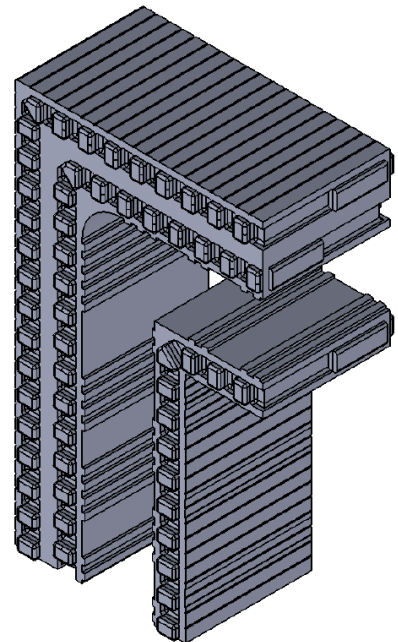
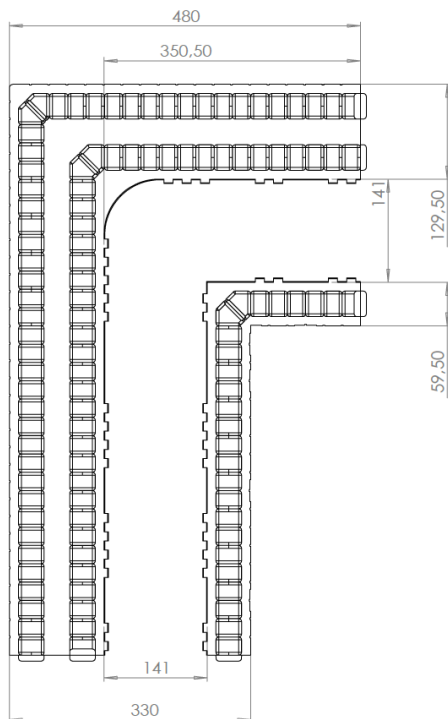

Outer corner Passief Bouwblok 330 element

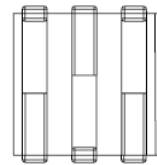
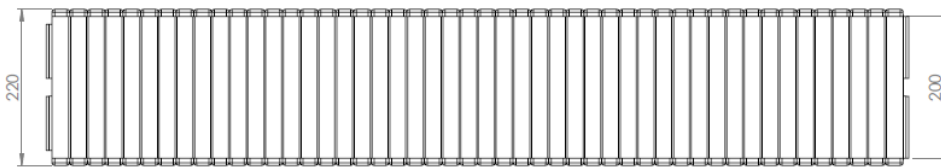
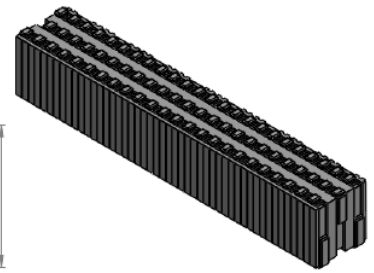
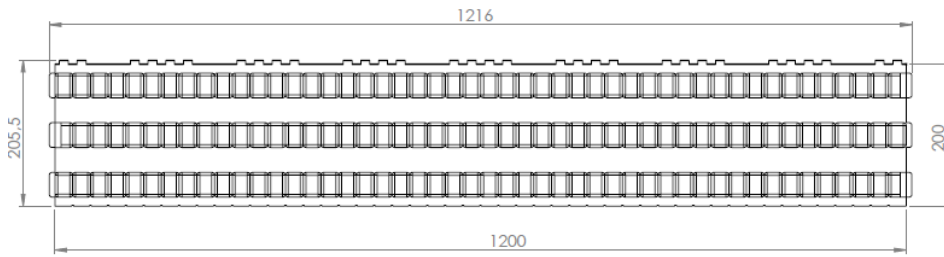

Fitting piece Passief Bouwblok 400 outerleaf

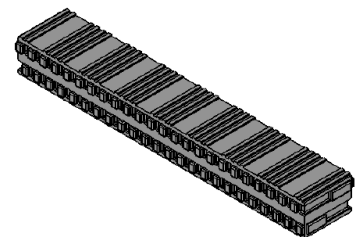
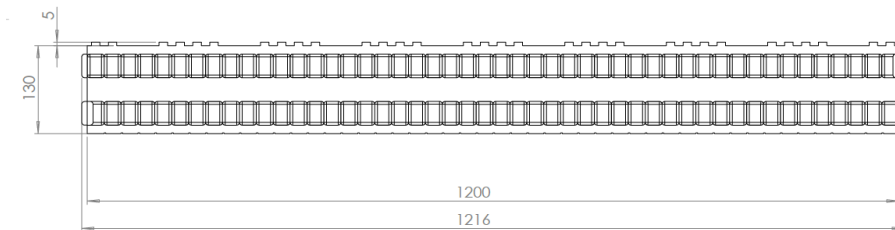
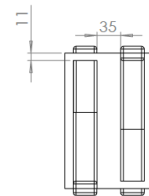
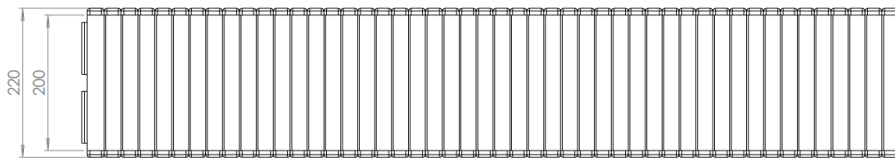

Fitting piece Passief Bouwblok 330 outerleaf

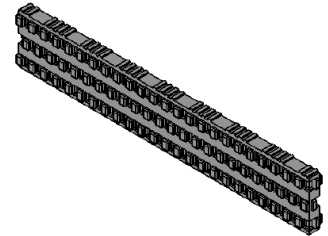
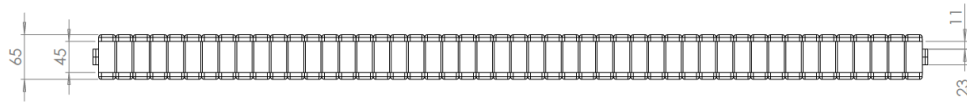
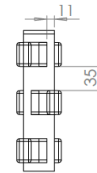
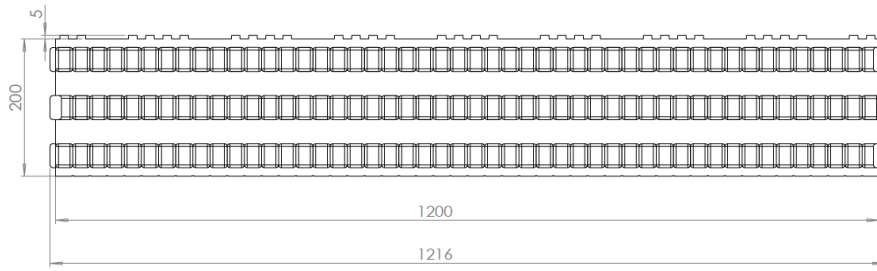

Fitting piece Passief Bouwblok outer leaf 400

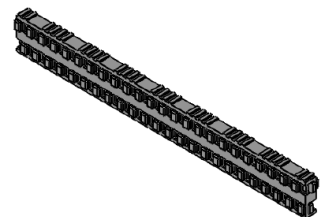
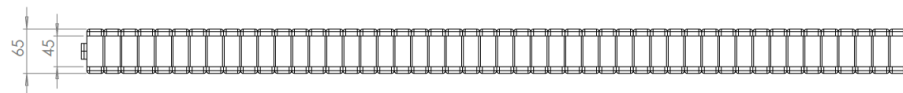
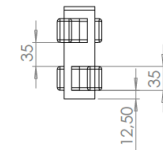
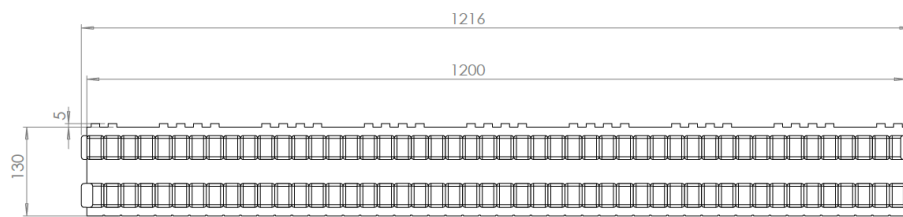

Fitting piece Passief Bouwblok outer leaf 330

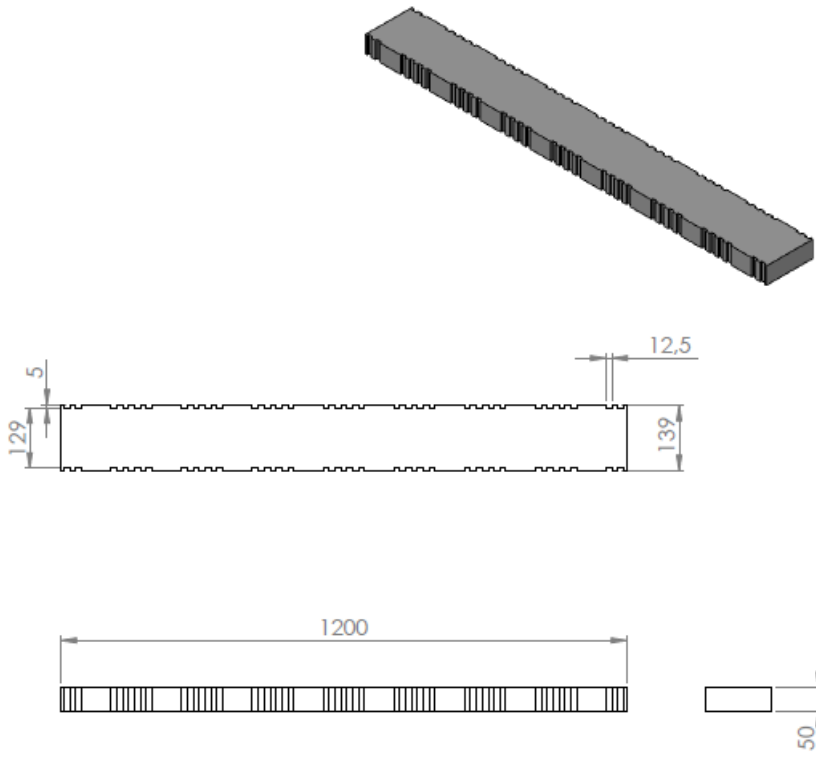

Horizontal Passief Bouwblok cavity capping element

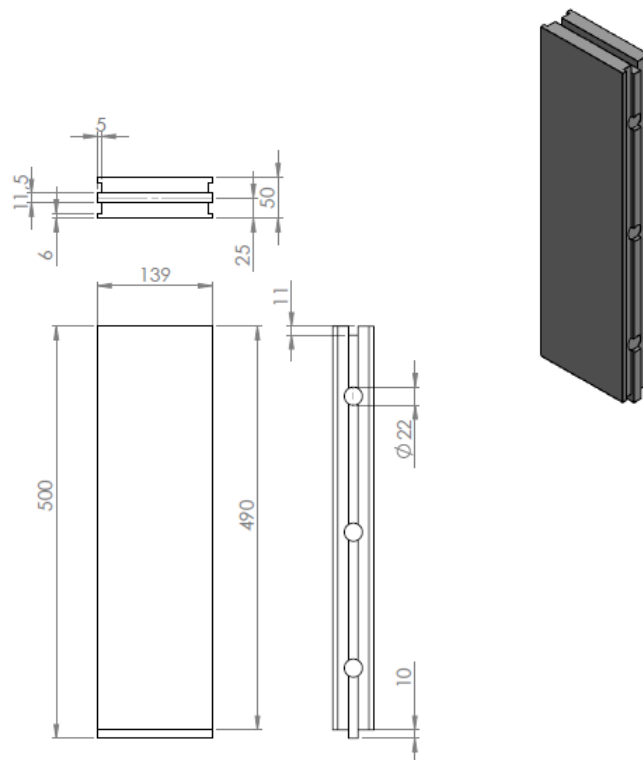

Vertical Passief Bouwblok cavity capping element

Annex B – Assembly details

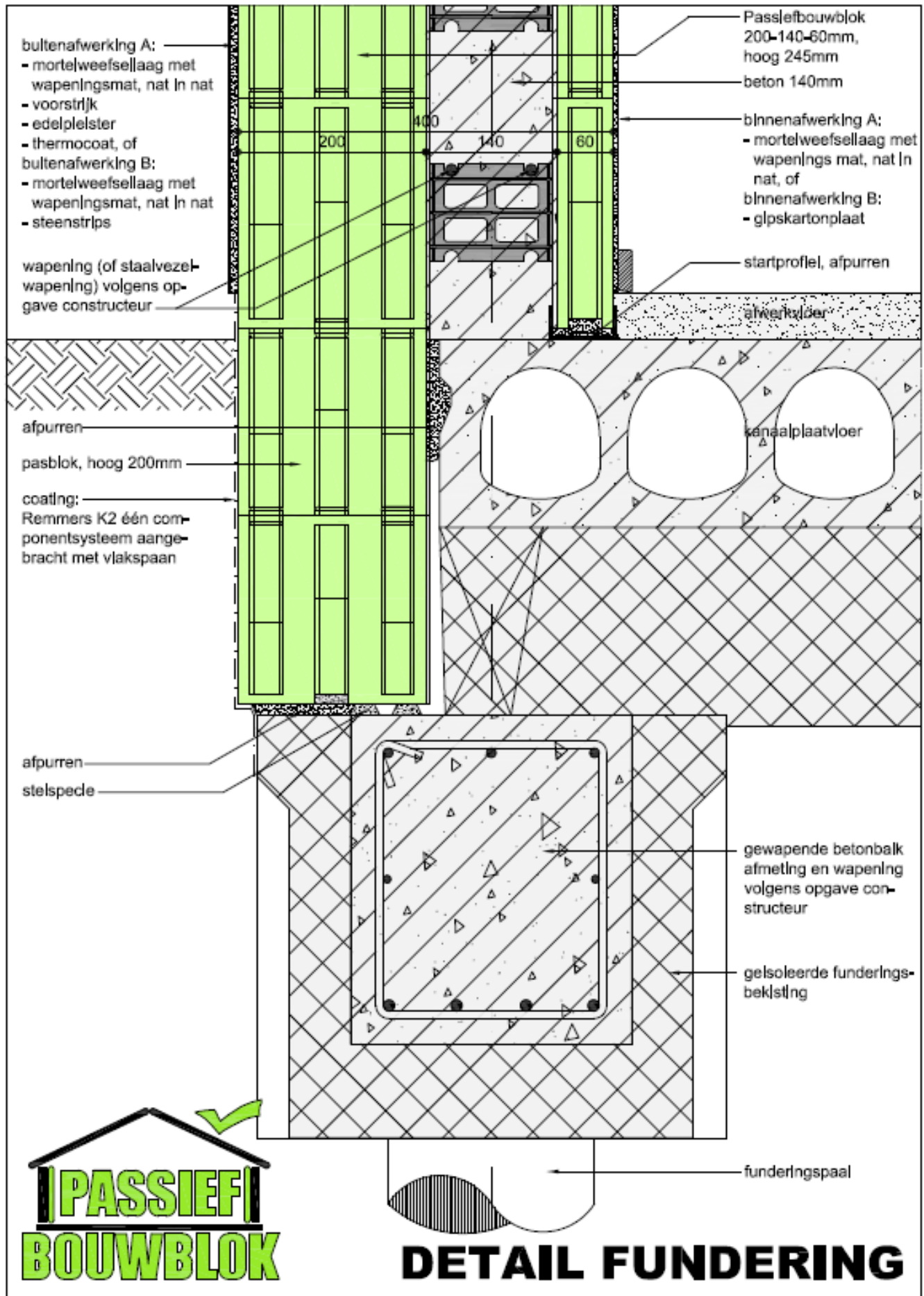

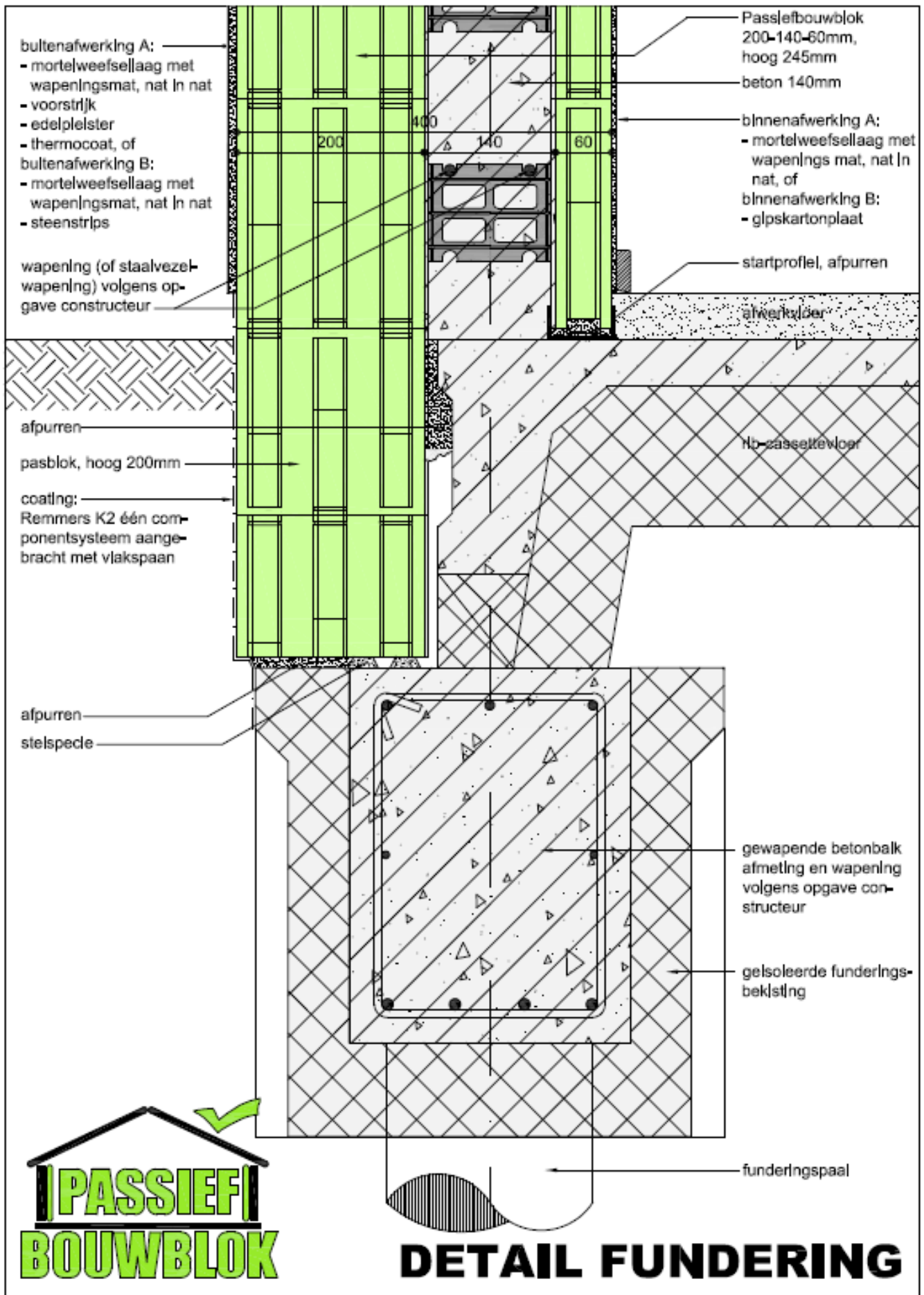

DETAIL FUNDERING

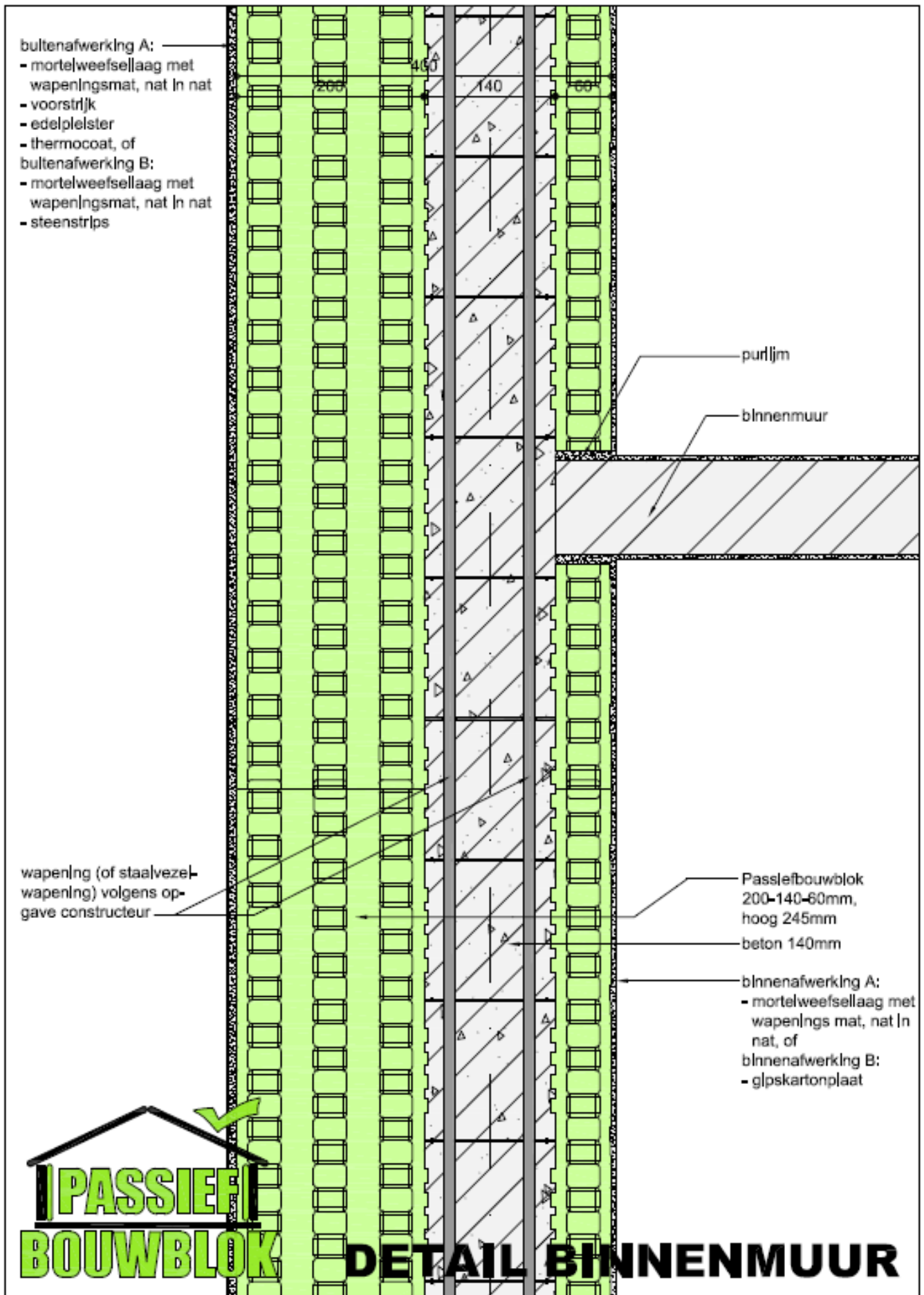

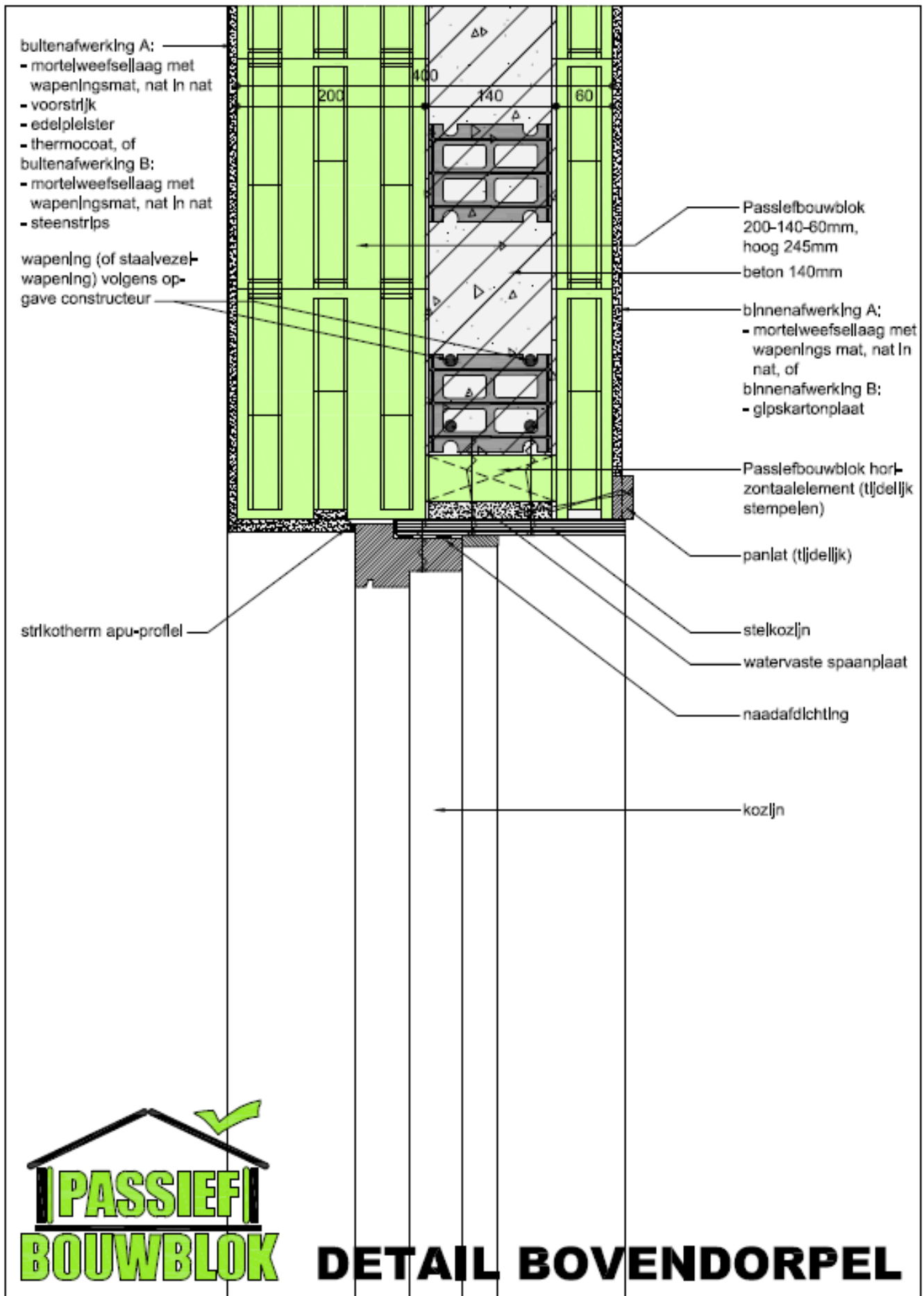

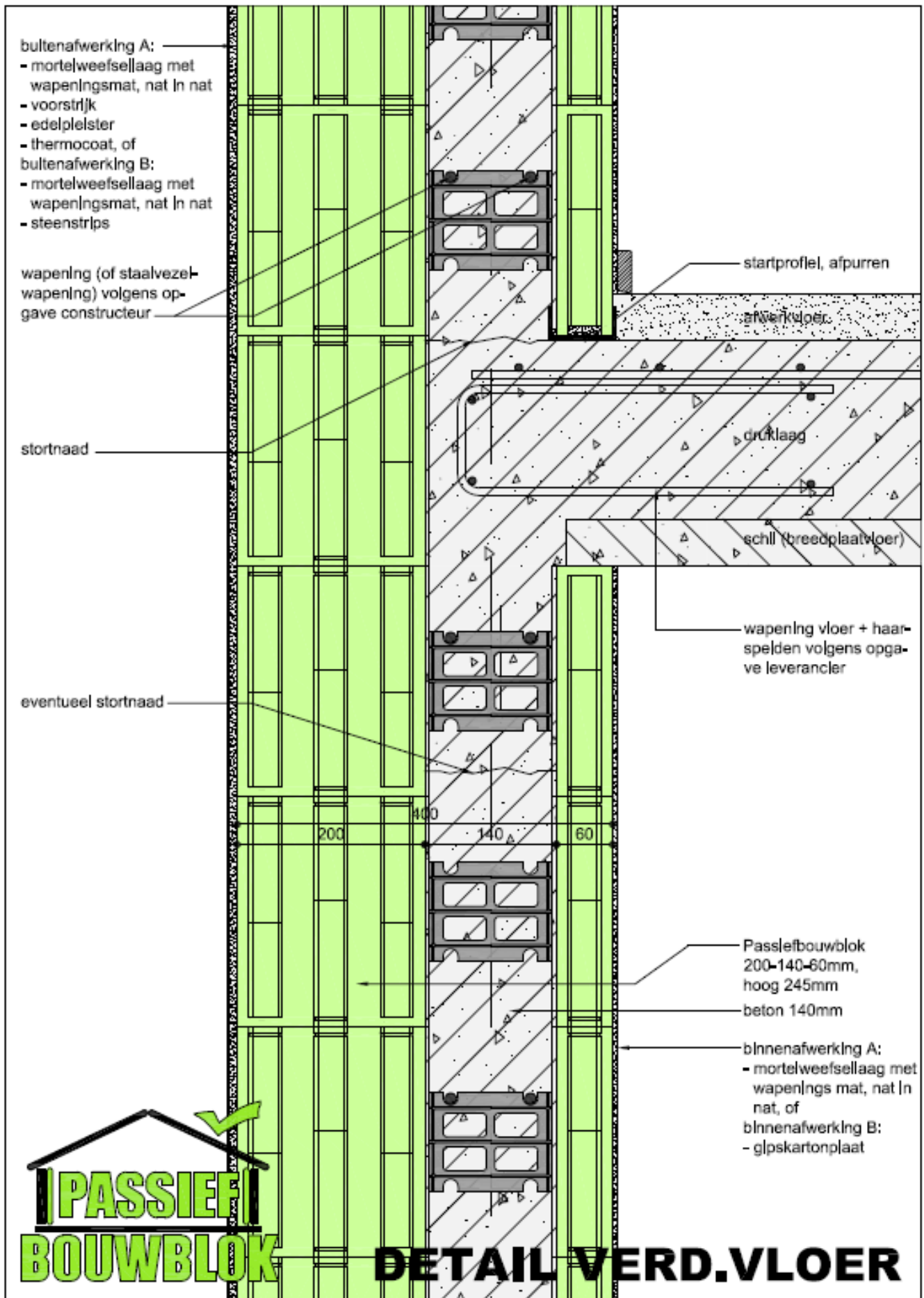

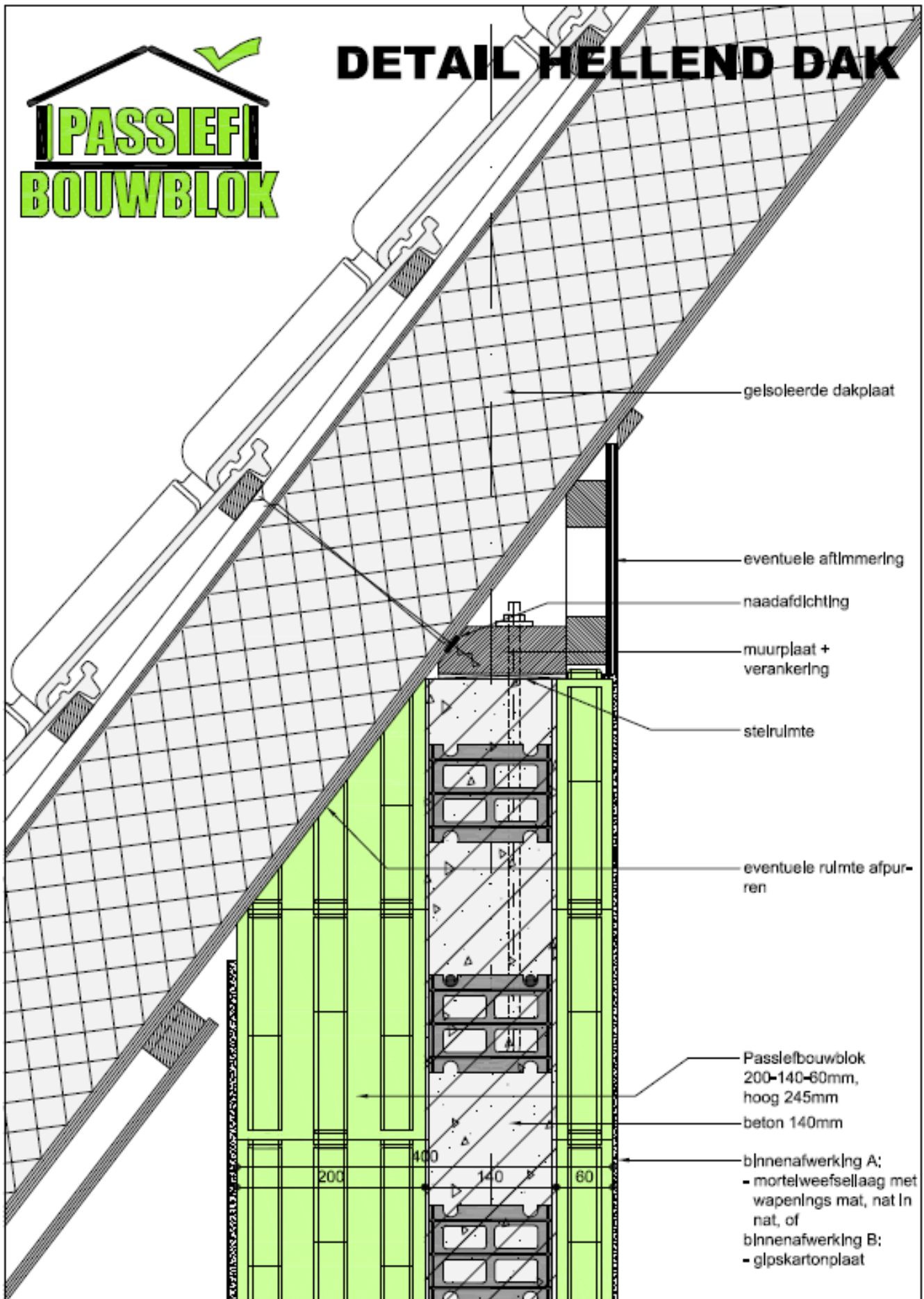

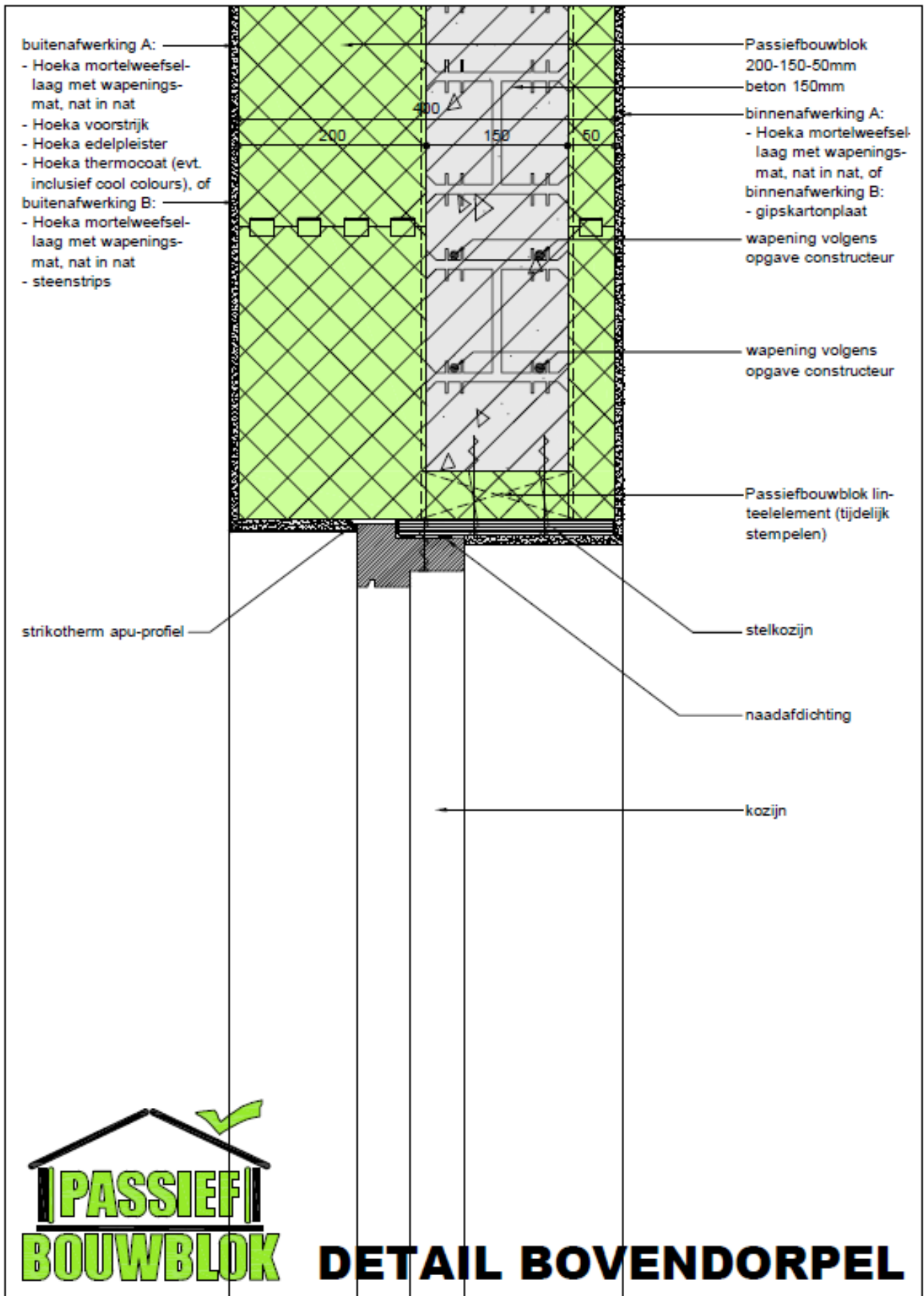

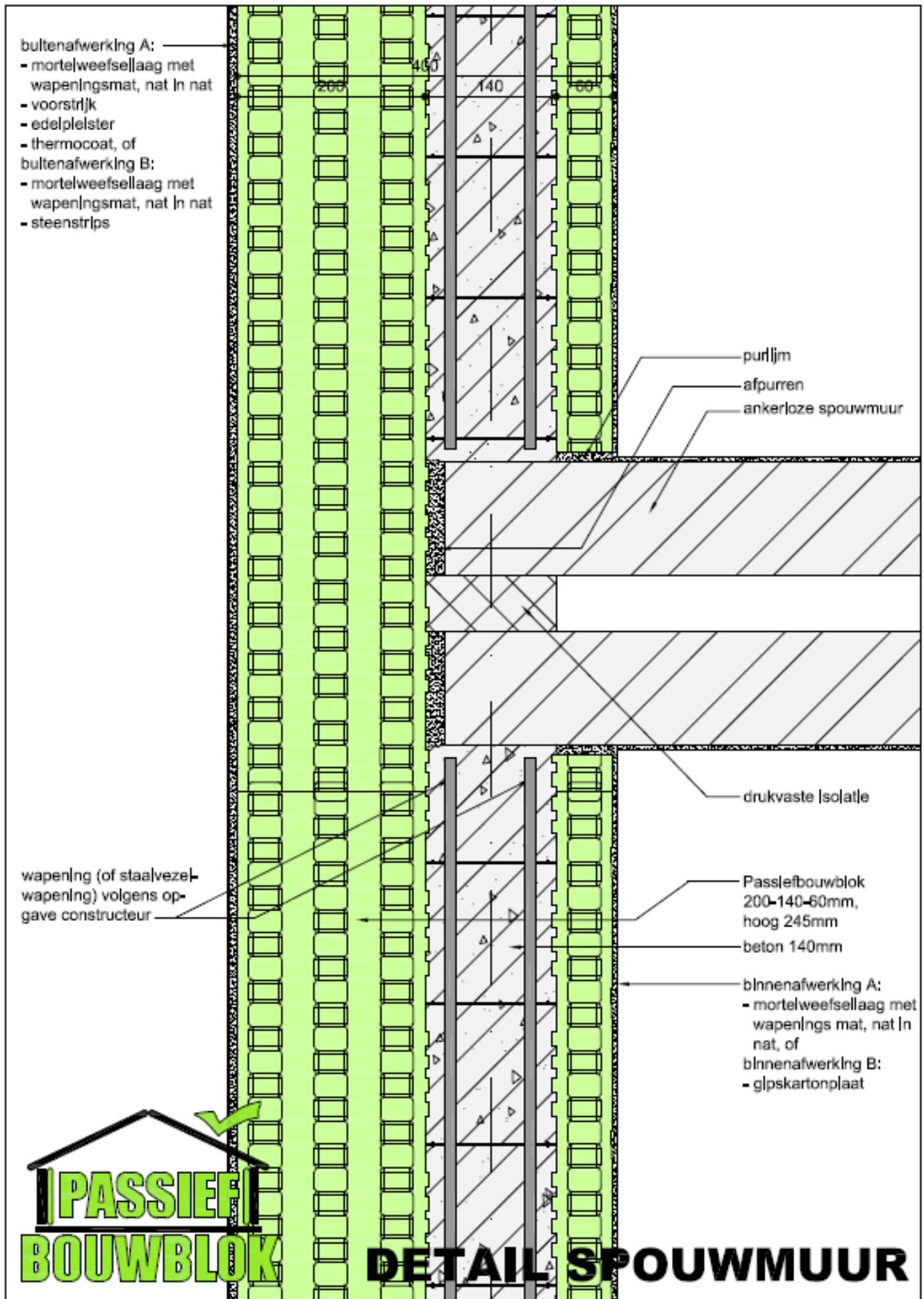

Annex C – Installer recommendations

Manufacturing

The shuttering elements are manufactured in accordance with the provisions of this ETA using the manufacturing process as identified during the inspection of the manufacturing plants by the approval body and laid down in the technical documentation.

Installation

Installation of the shuttering elements

The shuttering elements are put together on site in layers without mortar or adhesive. The elements shall be installed with staggered vertical joints, where the distance between joints in adjacent layers is minimum one quarter of the element length.

The levelling to the subsoil is performed according to the installation guide of the ETA-holder.

If required, bracings according to the installation guide of the ETA-holder are to be used in order to keep the walls aligned vertically during the installation. The bracing supports are then placed on the inner side of the wall at a maximum distance of 1.20 m.

Installation of the reinforcement

The necessary steel reinforcement according to static calculation shall be installed. Minimum and maximum distance between reinforcing bars and the required concrete cover shall be in accordance with EN 1992-1-1 or corresponding national rules.

Concrete

The maximum aggregate size shall be 16 mm and the slump class of the concrete shall be S4 according to EN 206-1 table 3. The concrete shall have rapid or middle strength development according to EN 206-1 table 12. Pouring the concrete shall only be performed by persons who have been introduced in the works and in the proper handling of the shuttering system.

When no bracing supports are foreseen, pouring the concrete shall be performed in layers of 1 m at an average vertical concreting rate of 1.6 m/h.

After the concrete has been poured the wall's deviation from a vertical line should not be more than 5 mm per running meter of the wall height.

Requirements

The fitness for use of the system can be assumed if the elements are installed correctly in accordance with the following requirements:

- installation is carried out under the direction of personnel trained and qualified and verified as competent to install the product by the ETA holder or its agent
- installation is in accordance with the ETA-holder's Installation Guide
- the specified products and accessories are used.

Recommendations on packaging, transport and storage

The ETA-holder's instructions regarding transport and storage shall be followed.

The shuttering elements shall be handled and stored with care, protected from accidental damage.

Before the installation, it shall be verified that elements have not been damaged during transport or storage.

Damaged elements shall be replaced by sound ones.

Recommendations on use, maintenance, repair

It is the responsibility of the ETA-holder to ensure that proper information for the use of the shuttering elements is available at each delivery, including general guidance on the basis of this ETA and the specific installation plans and construction details mentioned under '*Requirements*'.

Constitutive materials of the wall (concrete, insulating parts and spacers) do not induce specific problem of durability. But regular controls should be carried out on the outside rendering in order to be able to detect any damage and to repair it as quickly as possible.

The recommendation on use, maintenance and repair of ETAG 009 clause 7.5 shall be considered.